

**fullstop**<sup>®</sup>  
SECURITY

Thatcham<sup>®</sup>

Quality Assured

Category 3

**NEMESIS**

Model. FNU200

**ULTRA**

Wheel Lock



PLEASE READ THIS  
MANUAL BEFORE  
FIRST USE.

TIME INVESTED IN  
CORRECT FITMENT  
IS REPAID IN THE  
LEVEL OF SECURITY  
THAT IS ACHIEVED.

**User Manual**

Rev.A 12-12

by  **purpleline**<sup>®</sup>  
design...innovate...improve

# Parts Identification & Fitting Diagrams

Fig. A

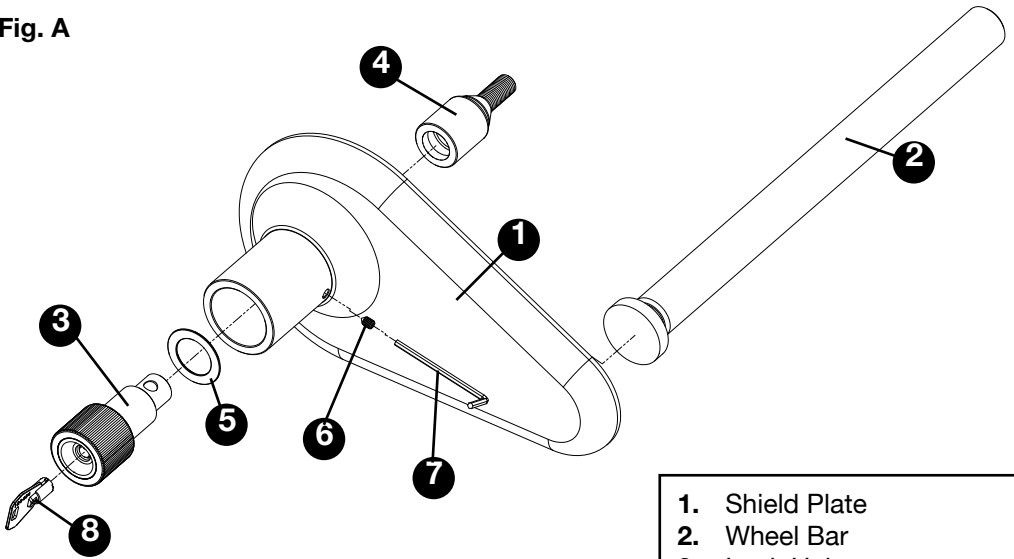

Fig. B

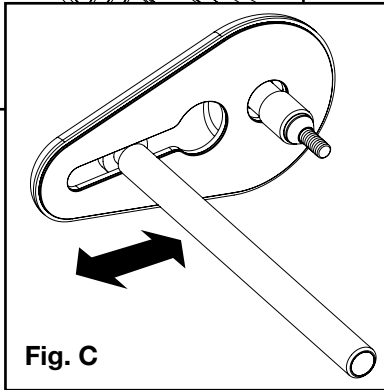
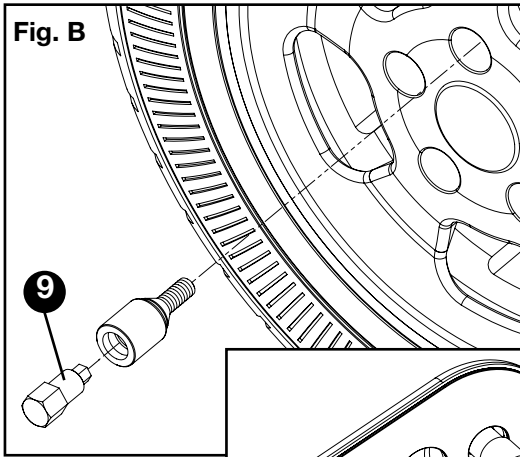
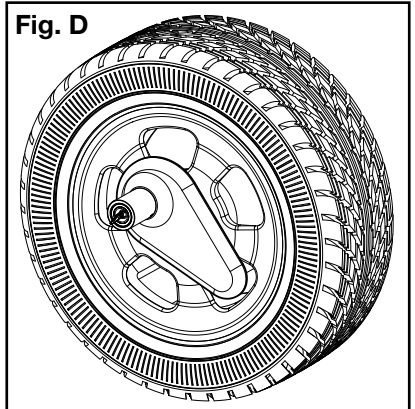

Fig. C

Fig. D



1. Shield Plate
2. Wheel Bar
3. Lock Unit
4. Receiver Wheel Bolt
5. 1mm Spacer Ring (x20)
6. Lock Unit Hex Screw
7. 3mm Hex Key
8. Key (x2)
9. 19mm Wheel Wrench Adapter

## Installation

The FullStop® Nemesis Ultra wheel lock is designed to secure the shield onto a replacement wheel bolt so that the Wheel Bar protrudes through one of the gaps in a wheel to prevent wheel rotation.

**1.** Before the product can be used, one of your existing wheel bolts must be removed and replaced with the Receiver Wheel Bolt (4). This replacement bolt has been designed to fit the majority of caravan road wheels, however, please check that your existing wheel bolts are of the same specification. The supplied Receiver Bolt (4) has a 12mm x 1.5mm thread pitch with a 60° conical seating. If in any doubt consult the caravan manufacturer or wheel supplier BEFORE installation as it is possible to damage the hub of the caravan if the screw threads do not match.

Once you have removed one of the wheel bolts, the Receiver Wheel Bolt (4) can be fitted using the Wheel Wrench Adapter (9) which enables you to use a standard wheel wrench that fits a 19mm hex head (see Fig.B).

The Receiver Bolt (4) should be tightened to the correct torque setting for your wheels. Note: Check your Owners Manual for details or consult a qualified technician. Do not over-tighten or use an impact wrench.

**2.** There are many possible combinations of how the Nemesis Ultra may fit to a particular wheel. Fig.C shows that the Wheel Bar (2) is designed to slide in or out as necessary depending on where the Receiver Bolt (4) has been installed in relation to which gap in the wheel's spokes the Wheel Bar (2) fits through. Note: When installing the device the Wheel Bar (2) should be located through the lower part of the wheel so that it does not hit the chassis or other obstruction (see Fig.D for guidance).

**3.** Before using the device it may be necessary to add Spacer Rings (5) to ensure that, when fitted, the back face of the Shield Plate (1) is as tight as possible to the face of the wheel when the Lock Unit (3) is locked into the Receiver Bolt (4).

To check this, first fit one of the keys into the Lock Unit (3) and rotate it through 90° clockwise which releases the locking ball bearings. You can now install the Lock Unit (3) through the aperture in the Shield Plate (1) as shown in Fig. A.

Offer up the assembly to the Receiver Bolt (4) and guide the end of the Lock Unit (3) into the Receiver Bolt (4) as far as it will go. Lock them together by rotating the key anti-clockwise through 90° and remove the key.

If the Shield Plate (1) is tight against the face of the wheel then no further adjustment is required. If, however, there is a gap between the back face of the Shield Plate (1) and the face of the wheel then Spacer Rings (5) must be used.

(cont overleaf)

## Installation (cont)

Try to gauge the amount of gap and add the necessary amount of 1mm thickness Spacer Rings (5) between the Shield Plate (1) and the Lock Unit (3) as shown in Fig.A.

If you add too many Spacer Rings (5) it will not be possible to fully engage the Lock Unit into the Receiver Bolt and rotate the key to lock it. If this happens then simply remove one Spacer Ring at a time until you achieve a secure fitment.

Once satisfied with the fit between the Shield Plate (1) and the face of the wheel, the Spacer Rings (5) can be retained in place by securing the Lock Unit (3) to the Shield Plate (1) by tightening the Lock Unit Hex Screw (6) using the supplied 3mm Hex Key (7).

4. The Nemesis Ultra is now ready for use. Please check the Receiver Bolt torque setting after the first 100 miles (approx) and at regular intervals thereafter.

## Maintenance

Spray the outside of the lock body with a light oil such as WD-40 or equivalent every sixteen weeks.

**Please store your keys in a safe place and remember to register your purchase. Your key number is located on both of the keys supplied and will be required in order to purchase replacement keys.**

**Registration is quick and simple, go to  
[www.purpleline.co.uk/product-registration](http://www.purpleline.co.uk/product-registration)**

### Disclaimer

If used properly, your FullStop® product will be an effective deterrent. However, nothing can stop the efforts of the most determined thief, and to this end no liability is accepted for any loss and/or damage caused by any illegal activity including theft or vandalism. Liability is also not accepted for any loss and/or damage arising from misuse, unauthorised repair or alteration and failure to follow the user guide directions. No form of consequential loss what so ever will be accepted.



© Copyright 2013. Purple Line Limited.

**Web:** [www.purpleline.co.uk](http://www.purpleline.co.uk) **E-mail:** [admin@purpleline.co.uk](mailto:admin@purpleline.co.uk) **Tel:** 01473 601200

Photographs for illustration purposes only. Actual product may differ slightly.

Purple line Limited reserve the right to alter product specification without prior notice.